



iQ500, built-under fridge, 82 x 60 cm, flat hinge KU15RAFF0G



Included accessories

1 x egg tray

Energy efficient undercounter fridge with handy covered fruit and Fresh Box

- ✓ LED light – Ample, even lighting helps you check what's in your fridge faster.
- ✓ The safetyGlass shelves are of extra strong, easy-cleaning safety glass.
- ✓ Additional space for fruit and vegetables: they stay crispy in the 2 Fresh Boxes with wavy bottom.

Features

Technical Data

Energy Efficiency Class: F
 Average annual energy consumption in kilowatt hour per year (kWh/a): 114 kWh/annum
 Sum of volume of frozen compartments: 0 l
 Sum of volume of chill compartments: 137 l
 Airborne acoustical noise emissions : 38 dB(A) re 1 pW
 Airborne acoustical noise emission class: C
 Built-in / Free-standing: Built-in
 Door panel options: Not possible
 Height: 820 mm
 Width of the appliance: 588 mm
 Depth: 548 mm
 Required niche size for installation (HxWxD): 820 x 600 x 550 mm
 Net weight: 34.1 kg
 Connection Rating: 90 W
 Fuse protection: 13 A
 Door hinge: Right reversible
 Voltage: 220-240 V
 Frequency: 50 Hz
 Approval certificates: CE, G-Mark, VDE
 Length electrical supply cord: 230 cm
 Number of compressors: 1
 Number of independent cooling systems: 1
 Interior ventilator: No
 Reversible Door Hinge: Yes
 Number of Adjustable Shelves in fridge compartment: 3
 Shelves for Bottles: Yes
 EAN code: 4242003848838
 Brand: Siemens
 Product name / Commercial code: KU15RAFF0G
 Product category: Refrigerator
 Frost free system: No
 Installation typology: Built-under





iQ500, built-under fridge, 82 x 60 cm, flat hinge KU15RAFF0G

Features

- Fully integrated

Functions

- Ventilation through plinth
- Easy clean interior

Design features

- Temperature control dial
- Automatic defrost in fridge section

Design features

- 3 safety glass shelves in fridge compartment of which 3 are height adjustable
- 3 removable door storage compartments.
- Bottle holder in x-deep door tray
- Bright interior LED fridge light
-

Freshness System

- 2 vegetable/salad containers
-

Key features - Fridge section

- Height adjustable feet in the front
- Right hinged door, door reversible
- Connection value 90 W
- 220 - 240 V

Dimension and installation

- Niche Dimensions: 82 cm H x 60 cm W x 55 cm D
- Dimensions: 82 cm H x 58.8 cm W x 54.8 cm D

Key features - Freezer section

- KU15RAFF0G

Additional features

Design features

Performance and Consumption

- EU19_EEK_D: F
- Total Volume : 137 l
- Net Fridge Volume : 137 l
- Net Freezer Volume : 0 l
- Annual Energy Consumption: 114 kWh/a
- Climate Class: SN-ST
- EU19_Fast freezer facility_D: no
- Noise Level : 38 dB



iQ500, built-under fridge, 82 x 60 cm, flat hinge KU15RAFF0G

Dimensioned drawings

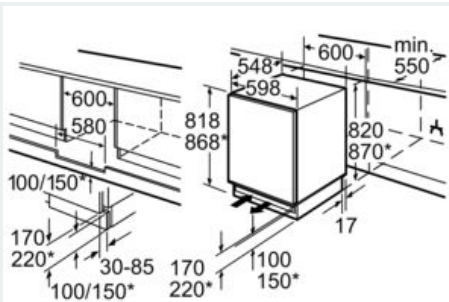

* variable base/substructure height

Space for electrical connection next to the appliance on the left or right-hand side.
Ventilation space in the base.

measurements in mm



Maximal permissible weight of the unit fronts

Fitted unit fronts that exceed the permissible weight may cause damage and result in functional impairment of the hinges.

Δ Weight
 A: Appliance door height including hinges in mm
 B: Undamped hinge, unit front in kg
 C: Damped hinge, unit front in kg

A	B	C
1500-1750	22	22
720-1400	19	19
A1	15	19
A2	15	19

measurements in mm Recommended gap dimensions for flat hinges

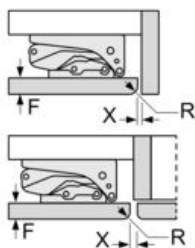

F	R	X
16-19	0-3	2.5
20	0-1	3
	2-3	2.5
21	0-1	3
	2-3	2.5
22	0	4
	1	3.5
	2-3	3

The gap dimensions recommended in the table must be adhered to in order to ensure that appliance doors do not collide with anything when they are opened, and to avoid causing damage to kitchen units.